



WHITE PAPER

Form 3 Design Guide

A good print starts with a well-designed model that is optimized for 3D printing. We've created this design guide to outline some of the minimum features you can expect from the Form 3.

The guidelines below have been developed using Formlabs Clear Resin printed at 100m microns. You may experience slight variations with other Formlabs Resins and at other layer heights.

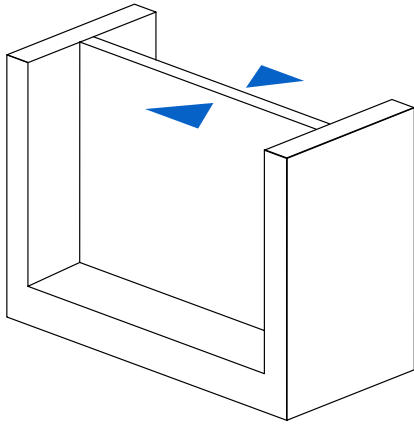

MINIMUM SUPPORTED WALL THICKNESS

Recommended: 0.2 mm

A supported wall is one that is connected to other walls on two or more sides. A supported wall smaller than 0.2 mm may warp during the peel process. Test walls were 25 mm x 25 mm.

Note: Washing Thin Walls

Care should be taken when washing thin walls, as they may absorb IPA and swell during the cleaning process, leading to deformation of the part. Minimizing time immersed in IPA will limit this effect.

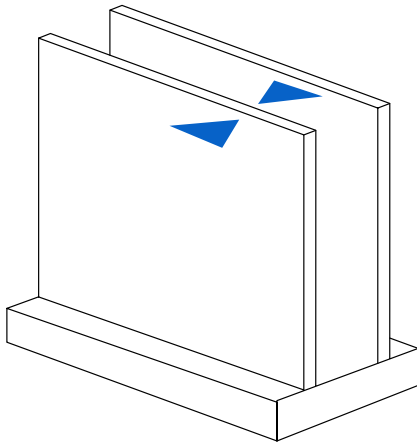

MINIMUM UNSUPPORTED WALL THICKNESS

Recommended: 0.2 mm

An unsupported wall is one that is connected to other walls on fewer than two sides. An unsupported wall that is smaller than 0.2 mm may warp or detach from the model during printing. Test walls were 25 mm x 25 mm.

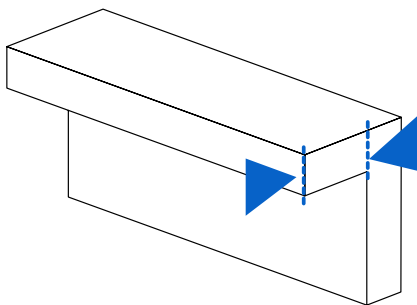

MAXIMUM UNSUPPORTED OVERHANG LENGTH

Recommended: 5.0 mm

An overhang refers to a part of the model that sticks out horizontally parallel to the build platform. Printing such features without supports is discouraged, as the layers cannot maintain their structure. Horizontal overhangs will be slightly deformed beyond 1 mm and become increasingly deformed as the length of the overhang increases. You can turn on “internal supports” in PreForm to ensure your overhangs are supported.

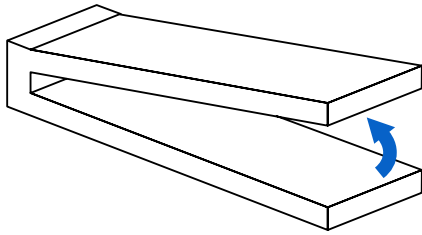

MINIMUM UNSUPPORTED OVERHANG ANGLE

**Recommended: 10° from level
(35 mm long × 10 mm wide × 3 mm thick)**

The overhang angle refers to the angle from horizontal that the overhang sticks out. Printing at an angle less than 10° could cause the overhang to break off the model during the peel process. Rotate your part so flat surfaces can be held up by supports if they are not already self-supporting.

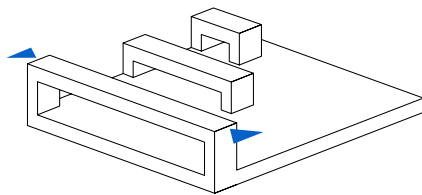

MAXIMUM HORIZONTAL SUPPORT SPAN/BRIDGE

Recommended: 29 mm (5 mm wide × 3 mm thick)

A span is the distance between two intermediate supports of a structure. While printing horizontal spans is discouraged, certain geometries print well. For a 5 mm wide and 3 mm thick beam, spans longer than 29 mm are likely to fail. Wider beams must be kept shorter to avoid breaking during the peeling process.

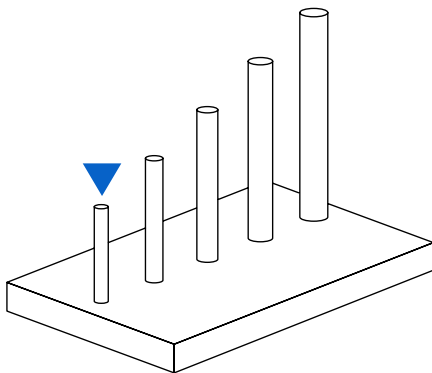

MINIMUM VERTICAL-WIRE DIAMETER

**Recommended: 0.2 mm (7 mm tall) to 1.5 mm
(30 mm tall)**

A wire is a feature whose length is greater than two times its width. The ratio is key to printing wires; at 0.2 mm thickness you can print up to 7 mm tall before you start to see waving. 1.5 mm wires can get up to 30 mm tall without defects.

Note: Washing Small Wires

Similar to washing thin walls, extra care should be taken when washing small wires, as they are weakened by IPA and can easily be damaged. Minimizing the time the part is immersed in IPA will limit this effect.

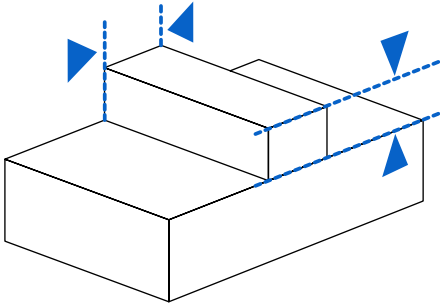

MINIMUM EMBOSSED DETAIL

Recommended: 0.1 mm

Embossed details are shallow raised features on your model, such as text. Details smaller than 0.1 mm in thickness and in height may not be visible on your print.

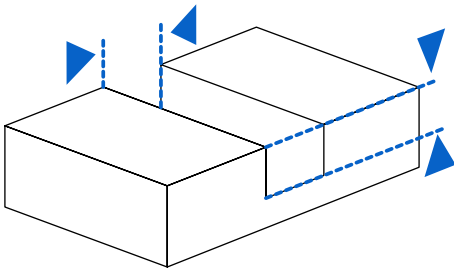

MINIMUM ENGRAVED DETAIL

Recommended: 0.15 mm

Engraved details are imprinted or recessed features on your model. Details recessed less than 0.15 mm in thickness and in height may not be visible because they will be fused with the rest of the model during the print process.

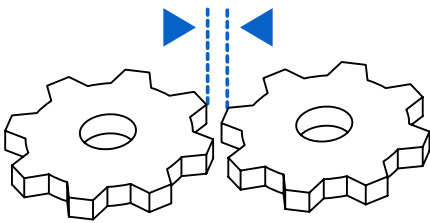

MINIMUM CLEARANCE

Recommended: 0.5 mm

Clearance is the amount of distance needed between two moving parts of a model (e.g., the distance between gears or joints). A clearance of less than 0.5 mm may cause parts to fuse.

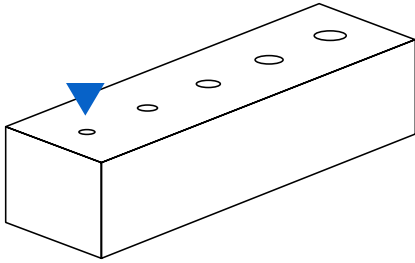

MINIMUM HOLE DIAMETER

Recommended: 0.5 mm

Holes with a diameter less than 0.5 mm in the x, y, and z axes may close off during printing.

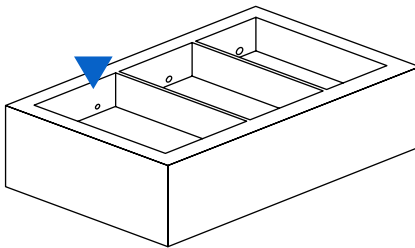

MINIMUM DRAIN HOLE DIAMETER

Recommended: 2.5 mm diameter

Drain holes are recommended for resin to escape in models that are a fully enclosed cavity (like a hollow sphere or hollow cylinder printed directly on the build platform). Without drain holes of at least 2.5 mm in diameter, the part may trap resin and lead to an explosion of the print. Although drain holes are recommended, they are not entirely necessary when using a Form 3 printer.